



Drilling Angles shown are for 5" PAP – Adjust for other PAPs

Evil Eye Pearl Drilling Chart							
	Layout	Layout Specs	Low RG	Int Diff	Total Diff	Differential Ratio	RG PAP
	Undrilled	-	2.493	0.000	0.045	0.00	
A	Maximum Performance	Pin Over 70° x 3-1/2" x 20°		0.022	0.057	0.39	2.513
B	Strong Performance	Pin Over 75° x 4" x 30°		0.023	0.053	0.43	2.518
C	Strong Control	Pin Over 80° x 4-1/2" x 40°		0.021	0.046	0.46	2.521
D	Maximum Control	Pin Beside 90° x 2 1/4" x 45°		0.014	0.044	0.32	2.502
E	Strong Continuous	20° x 3-1/2" x 20°		0.007	0.047	0.15	2.512
F	Versatile Continuous	20° x 5" x 30°		0.009	0.043	0.21	2.527

Differential Ratio relates to the reaction to friction, the higher the diff ratio the more responsive the ball will be to friction.

Performance Enhanced Drilling (PED) – Placing the center of the thumb 6.5 in. from the pin, on a line drawn from the pin through the CG, yields the highest intermediate differential by **hitting the core protrusion**.

Performance Control Drilling (PCD) – Placing the center of the thumb 5.5 in. from the pin, on a line drawn from the pin through the CG, yields a moderate intermediate differential by **hitting part of the core protrusion**.

Symmetrical Continuous Drilling (SCD) – Placing the center of the thumb at least 3.75 in. from the line drawn between the pin and CG (see diagram) **misses the core protrusion** and yields the lowest intermediate differential.

Suggested Super Symmetric Layouts

Performance Enhanced Drilling (PED)

A – Maximum Performance

- 70° x 3-1/2" x 20°
- Thumb Center is 6.5" from Pin

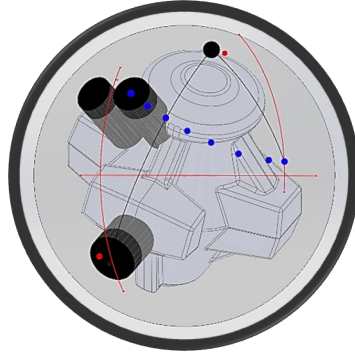

B – Strong Performance

- 75° x 4" x 30°
- Thumb Center is 6.5" from Pin

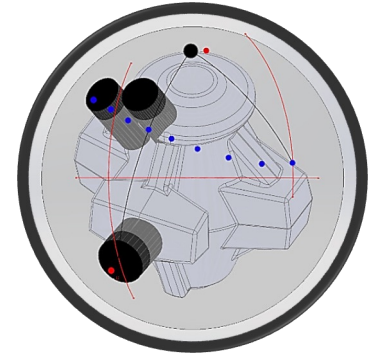

Performance Control Drilling (PCD)

C – Strong Control

- 80° x 4-1/2" x 40°
- Thumb center is 5.5" from Pin

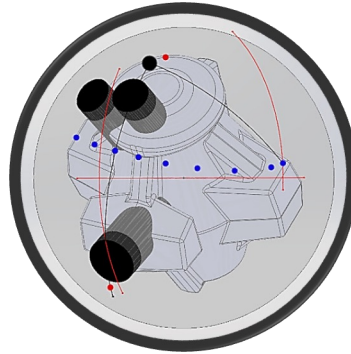

D – Maximum Control

- 90° x 2-1/4" x 45°
- Thumb center is 5.5" from Pin

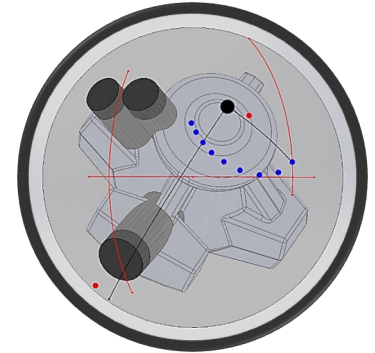

Symmetrical Continuous Drilling (SCD)

E – Strong Continuous

- 20° x 3-1/2" x 20°
- Thumb Center is 3.75" from Pin-Spin Line

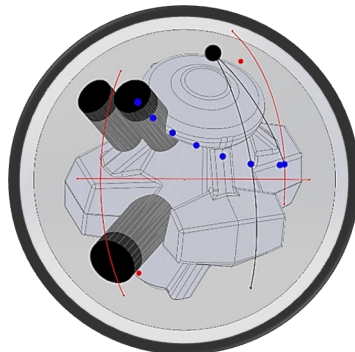

F – Versatile Continuous

- 20° x 5" x 30°
- Thumb Center is 4" from Pin-Spin Line

